

## Fiches techniques GRC

---

### Features of GRC

---

Light weight due to thin section  
Design flexibility  
Non-combustibility  
Anti-corrosiveness  
High bending strength  
High impact strength

---

### Typical properties of GRC

There are mainly two kinds of GRC classified by their [process](#), one is Spray-up GRC, the other is Premix GRC. Typical properties of each GRC are shown in the Table below. All values shown in the Table are only for reference and not used for design. All GRC are not always satisfy the values because of various mix proportions and QC.

### Process of GRC

[ Spray Process ]

Spray-up GRC is produced by using spray gun which sprays mortar fed from a "mortar" pump and "glass fibers" cut in the spray gun from [Roving](#). And then , sprayed GRC is compacted by roller.

Sprayed GRC required spray gun, Mixer, mortar pump and air compressor. Outline of the process is as follows. We [link](#) to UK spray equipment manufacture -- Power-Sprays Ltd.

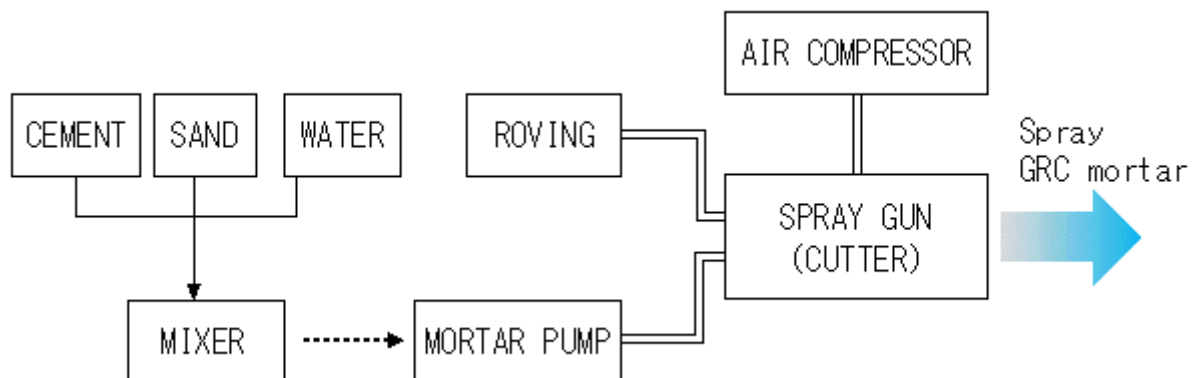

Process			Spray-up	Premix	
ARG fiber content		(wt. %)	5	3	
Density (air dried state)		(g/cm <sup>3</sup> )	1.8 -- 2.2	1.7 -- 2.1	
Strength	Bending	<a href="#">MOR</a>	(MPa)	20 -- 30	10 -- 20
		<a href="#">LOP</a>	(MPa)	7 -- 13	5 -- 10
		Modulus of Elasticity	(GPa)	15 -- 25	13 -- 21
	Tensile	<a href="#">UTS</a>	(MPa)	10 -- 15	4 -- 7
		<a href="#">BOP</a>	(MPa)	5 -- 7	3 -- 5
	Shear	Out-of-plane	(MPa)	20 -- 30	4 -- 6
		In-Plane	(MPa)	7 -- 12	4 -- 6
		Interlamainar	(MPa)	2 -- 4	4 -- 6
	Charpy Impact Strength		N·mm/mm <sup>2</sup>	15 -- 25	7 -- 12
Water	Water Absorption		(%)	10 -- 15	10 -- 15
	Drying Shrinkage		(%)	0.1 -- 0.2	0.1 -- 0.2
Heat	Thermal conductivity		(W/m·K)	0.9 -- 1.5	0.9 -- 1.5
	Thermal Expansion Coefficient		(X10 <sup>-6</sup> /°C)	7 -- 12	7 -- 12
Fire	Incombustibility		Incombustible		

MOR : Modulus Of Rupture

LOP : Limit Of Proportionality

UTS : Ultimate Tensile Strength